

**Fit Anywhere.  
Perform Everywhere.**

KMMK delivers a differentiated line of compact, and performance-optimized connectors paired with proprietary cables, built to provide a true "fit-anywhere" solution that offers uncompromized signal integrity, exceptional reliability, and seamless functionality.

This approach is reflected across four core pillars:

1. Designed for space-constrained applications:  
Compact, purpose-built patented solutions designed for tight-envelope environments, while delivering reliable performance across a wide range of demanding applications.
2. Built for demanding environments:  
Robust, reliability-focused designs, engineered to outperform standard off-the-shelf components in challenging conditions.
3. Premium performance, commercially competitive:  
High-end specifications, materials, and build quality delivered at accessible, market-aligned price points.
4. Vertically integrated OEM capabilities:  
In-house engineering and manufacturing of connectors and cables ensures stringent quality control, reduced lead times, and flexible custom and private-label solutions.

## Summary

SP Connectors * / Overview	4
SPXA Series / Angled XLR Connectors	5
SPX Series / Straight XLR Connectors	6
SPD Series / Angled + Straight DIN Connectors	7
SP Series / Angled 6.35mm Connectors	8
SPS Series / Straight 6.35mm Connectors	9
SPDC Series / Angled + Straight DC Power Connectors	10
SP3.5 Series / Angled + Straight 3.5mm Connectors	11
SP Connectors / Specifications	12
SP Connectors / Summary	14
SP Cables / Overview	15
01. Series / Quad-Core Balanced Microphone Cables	16
02. Series / Quad-Core Balanced Patch Cables	17
03. Series / Low Capacitance Instrument Cables	18
04. Series / Low Capacitance Pedalboard Cables	19
SP Cables / Specifications	20
SP Cables / Summary	23
Contact Info	24

---

\*SP stands for SquarePlug, a reference to our original square-shaped (or near square-shaped) 6.35mm angled connector “pancake” design that established the foundation of the series.

The name reflects the distinctive geometry that set these connectors apart in both form and function.

Throughout this document, “SP” will be used as the standard designation for the SquarePlug Connectors and SquarePlug Cables lines.

## SP Connectors The Standard In Ultra Compact Interconnects

SP Connectors offers the industry's most comprehensive selection of ultra compact, performance optimized Audio, DIN and DC Power connectors.

They provide a true "fit anywhere" solution for virtually any application, supporting both high density and standard clearance cabling.

Designed with a robust mechanical architecture and high integrity signal transmission, SP connectors ensure the long-term operational consistency, dependable performance, and durability essential for the most challenging audio environments.

## SPXA Series: angled xlr connectors

The SPXA angled XLR Series features a distinctive, compact, and ruggedized design engineered for maximum space efficiency and uncompromising reliability.

With no industry equivalent, this series represents the definitive choice for both space constrained and standard clearance applications, delivering unrivalled performance across stage, studio, broadcast, field recording, and system integration.

SPXA connectors feature our patented cable clamping mechanism for optimal strain relief, eight adjustable radial exit angles for precise routing in tight spaces, and a reinforced, ergonomic construction that ensures long term durability and reliable field handling.

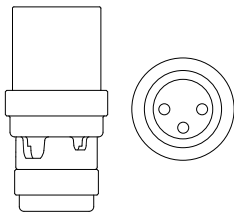

SPXA-M

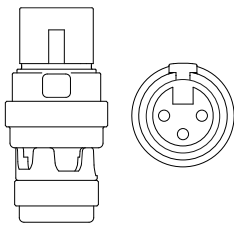
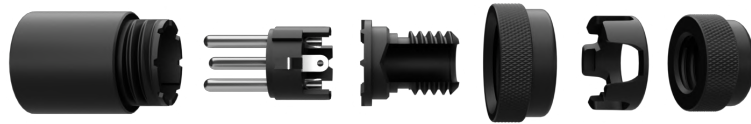

SPXA-F

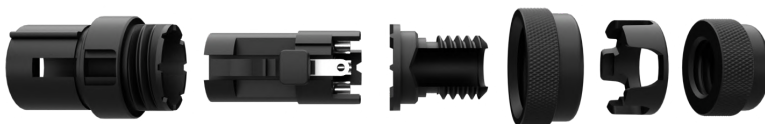

## SPX Series: straight xlr connectors

The SPX straight XLR series is engineered to optimize footprint efficiency (up to 30% shorter than conventional designs) while maintaining robust mechanical integrity and dependable field performance.

A precision chuck style clamping mechanism ensures secure cable retention and effective strain relief, while discreet, side mounted interchangeable fasteners allow for up to 55 distinct color coding configurations for clear visual identification.

The series utilizes the same heavy duty, ergonomically optimized construction platform as the SPXA range.

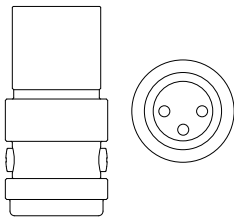

SPX-M

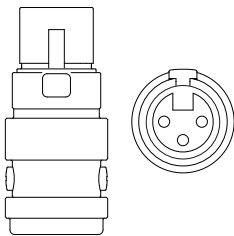

SPXA-F



## SPD Series: straight and angled din connectors

Built on the same compact, high performance architecture as our SPXA series, our SPDA angled DIN connectors deliver unmatched space efficiency without compromising functionality or durability.

As the only DIN connectors on the market offering such a small footprint, they incorporate our patented cable clamping system for optimal strain relief and feature eight adjustable radial exit angles for precise routing in tight environments.

A reinforced, ergonomic construction ensures long-term durability and reliable field handling, providing a robust, high performance solution for both standard and high density applications.

Available in 5 and 7 contact configurations.

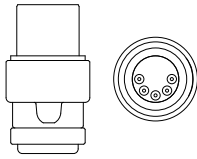

SPD5A

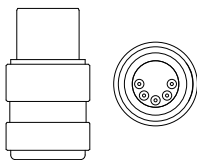

SPD5



## SP Series: 6.35mm angled ts and trs connectors

Introduced in 2016 with the SP400, our SP Series ultra low profile "flat" angled connectors set a new benchmark in 6.35 mm connector design.

Rapidly adopted by professional rig builders across the globe, the SP400 directly addressed two critical limitations of existing connectors at the time: bulky form factors, problematic for dense pedalboards and rack integrations, and inadequate cable retention systems that compromised strain relief and long-term reliability. The range has since expanded to include the SP500, SP550-S, SP600, and SP650-S, accommodating a wide range of cable diameters while preserving the same ultra-compact footprint and proven cable retention design.

The SP700 extends the platform to instrument cables, combining a compact footprint with an ergonomic design optimized for repeated mating cycles and reliable performance in live, studio, and touring environments. A chuck type strain relief system provides secure cable retention and isolates solder joints from mechanical stress, while accessible terminals allow fast assembly and easy servicing.

Today, the SP Series is widely recognized as the industry standard for pedalboard and rack integration, trusted by professionals worldwide.

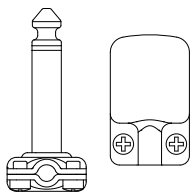

SP400

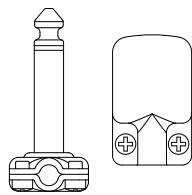

SP500

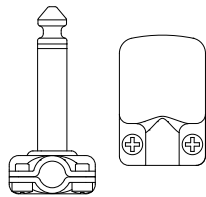

SP600

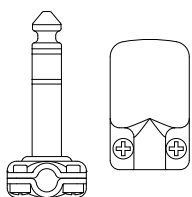

SP550-S

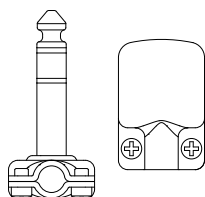

SP650-S

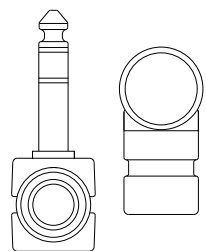

SP700

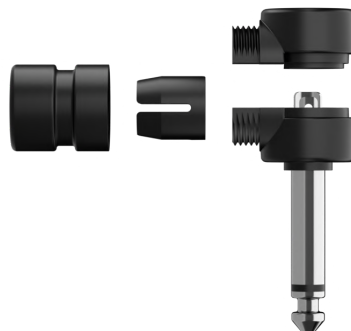
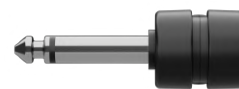

## SPS Series: 6.35mm straight ts and trs connectors

The SPS Series comprises the shortest solderable straight 6.35mm connectors in the industry, engineered for high density environments such as patch bays, switching systems, and compact signal routing setups.

A proprietary side screw based clamping mechanism ensures secure cable retention while enabling intuitive color coding for fast identification and organized signal management. Available in TS and TRS configurations, the series supports both unbalanced and balanced applications.

The new SPS7M extends the platform to instrument cables with a compact, ergonomically optimized design for intensive handling and repeated mating cycles in live, studio, and touring environments.

A chuck style strain relief system provides firm cable retention while isolating solder joints from mechanical stress, and the open terminal layout enables efficient assembly and straightforward servicing.

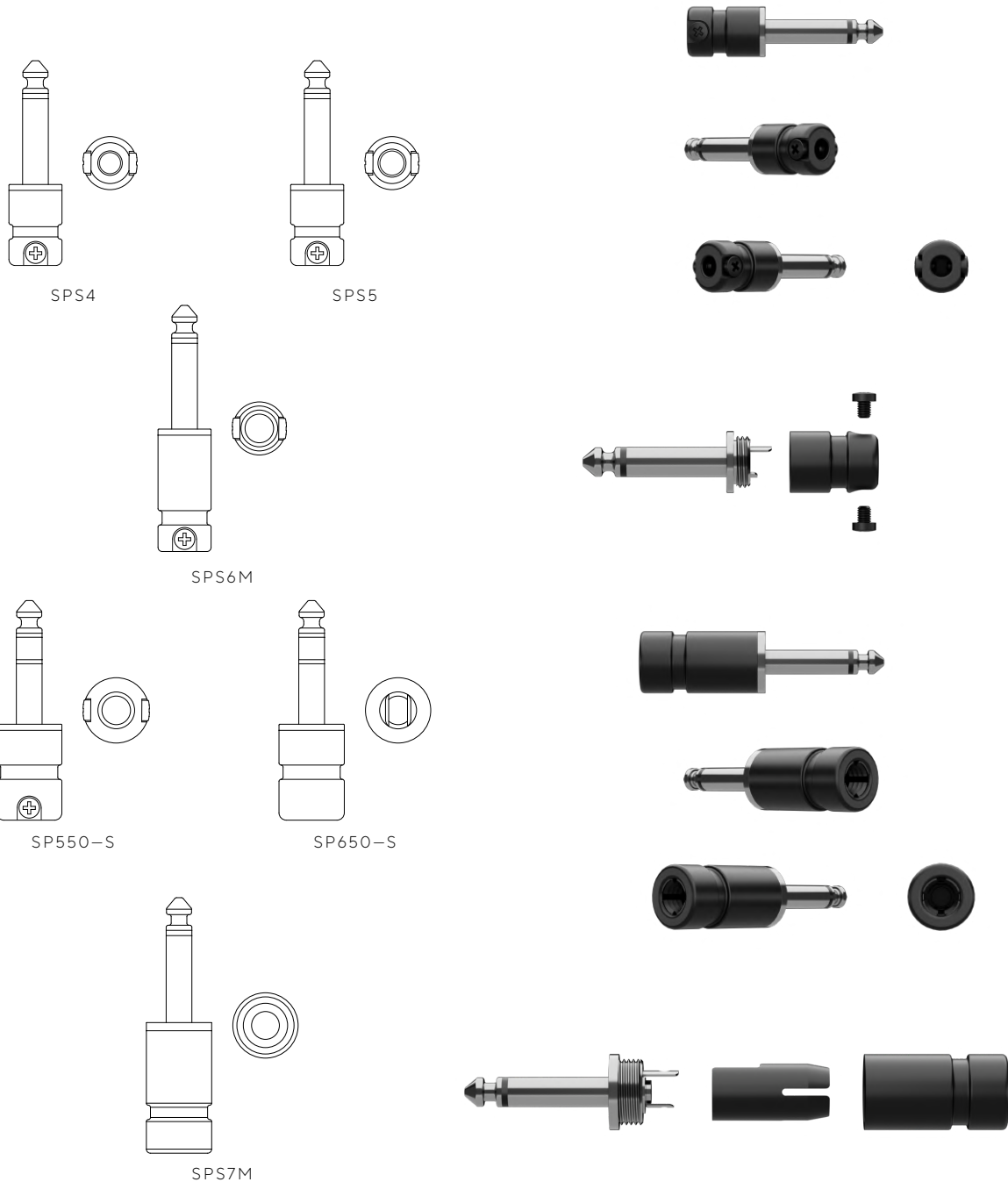

## SPDC Series: 2.1mm + 2.5mm angled and straight dc power connectors

SP DC Power Connector Series is engineered to overcome the mechanical and electrical limitations of conventional designs.

Typical solutions rely on lightweight plastic housings with minimal structural reinforcement, limited solderability, and inadequate or absent strain relief, resulting in poor handling characteristics and reduced durability under repeated use.

This series addresses these constraints through a robust all metal construction, an integrated adaptive strain relief system for secure cable retention, and properly engineered insulation between conductive components.

The result is a professional grade connector offering enhanced mechanical integrity, improved electrical safety, and consistent long term reliability in demanding applications.

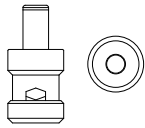

SPDC2.1A

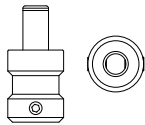
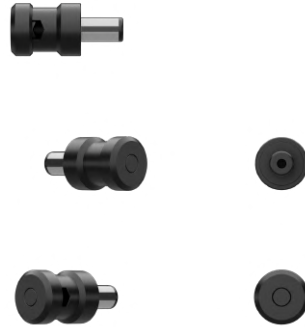

SPDC2.1

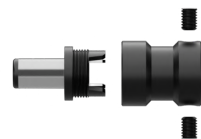

## SP3.5 Series: 3.5mm angled + straight ts and trs connectors

Built on the same compact, high performance platform as our DC power connector series, the 3.5 mm connectors are engineered for high density integration without compromising functionality or durability. They incorporate our patented adaptive cable clamping system to provide controlled strain relief and secure cable retention, along with a reinforced, ergonomically optimized construction for long term mechanical integrity and reliable field handling.

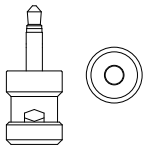

SP3.5

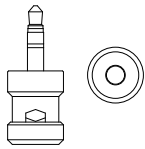

SP3.5-S

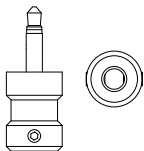

SPS3.5

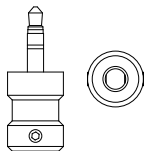

SPS3.5-S

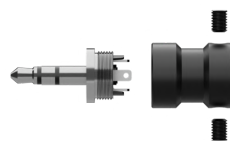

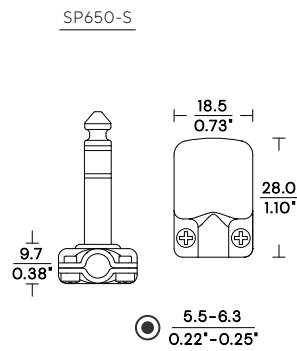
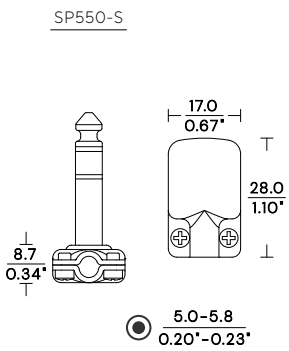
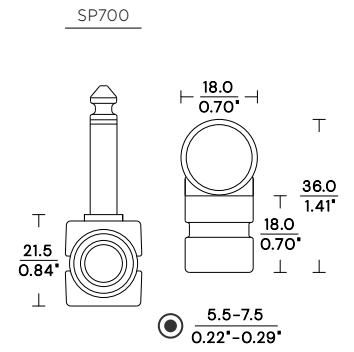
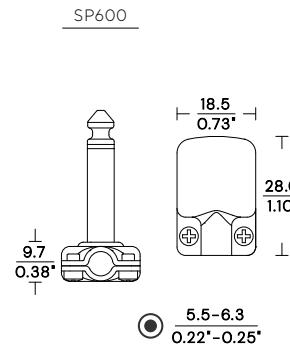
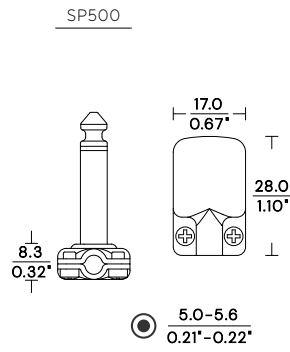
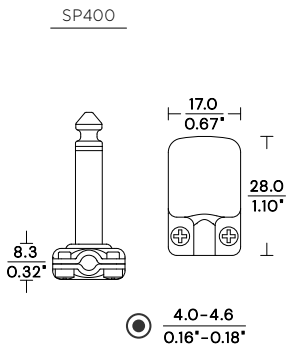
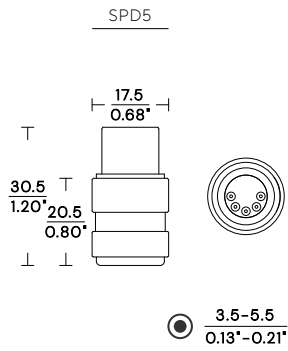
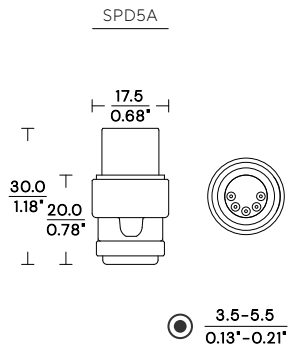
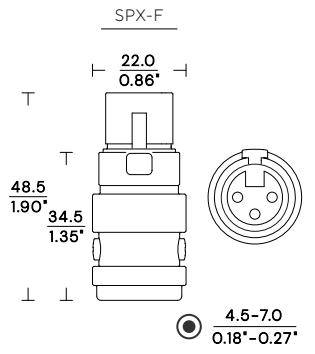
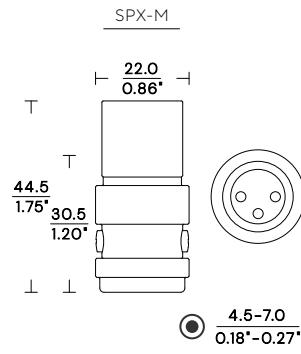
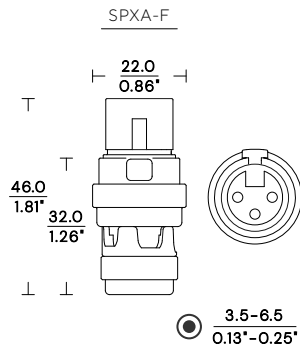
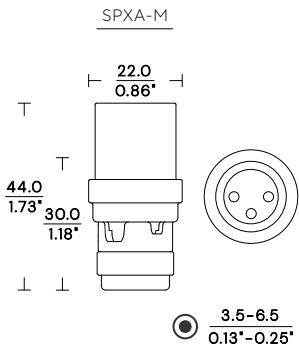

SPS4

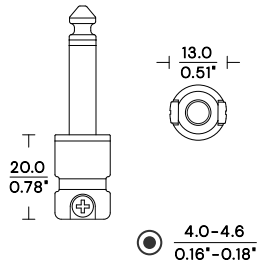

SPS5

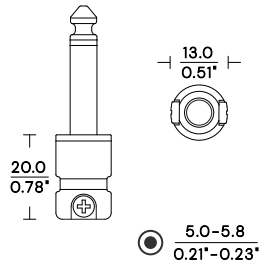

SPS6M

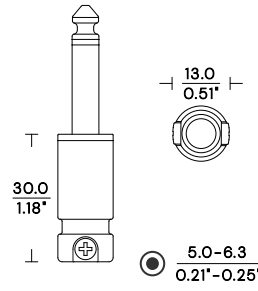

SPS7M

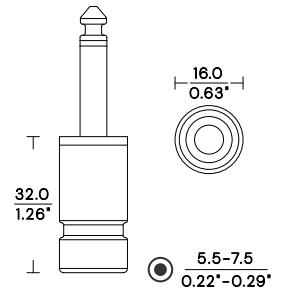

SPS6-S

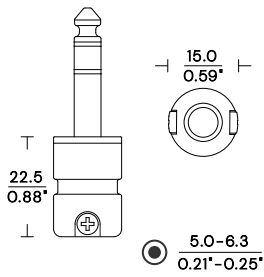

SPS7-S

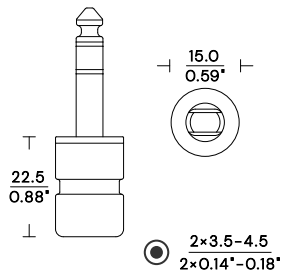

SPDC2.1A

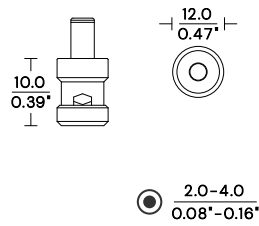

SPDC2.1

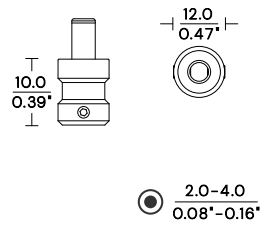

SP3.5

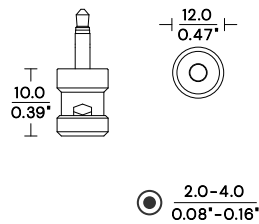

SPS3.5

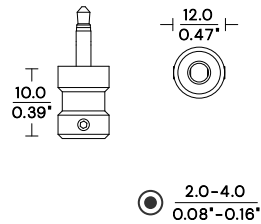

SP3.5-S

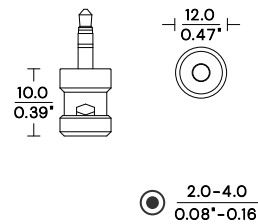

SPS3.5-S

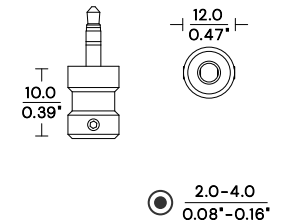

SKU	SERIES	TYPE	BLACK	SILVER	AVAILABILITY
SPXA-MBK	SPXA	ANGLED 3-POLE XLR MALE	☉		Y
SPXA-FBK	SPXA	ANGLED 3-POLE XLR FEMALE	☉		Y
SPX-MBK	SPX	STRAIGHT 3-POLE XLR MALE	☉		Y
SPX-FBK	SPX	STRAIGHT 3-POLE XLR FEMALE	☉		Y
SPD5A	SPD	ANGLED 5-POLE DIN	☉		Y
SPD5	SPD	STRAIGHT 5-POLE DIN	☉		Q3 26
SPD7A	SPD	ANGLED 7-POLE DIN	☉		Q4 26
SPD7	SPD	STRAIGHT 7-POLE DIN	☉		Q4 26
SP400	SP	ANGLED 1/4" TS		☉	Y
SP400BK	SP	ANGLED 1/4" TS	☉		Y
SP500	SP	ANGLED 1/4" TS		☉	Y
SP500BK	SP	ANGLED 1/4" TS	☉		Y
SP600	SP	ANGLED 1/4" TS		☉	Y
SP600BK	SP	ANGLED 1/4" TS	☉		Y
SP700	SP	ANGLED 1/4" TS		☉	Q4 26
SP700BK	SP	ANGLED 1/4" TS	☉		Q4 26
SP550-S	SP	ANGLED 1/4" TRS		☉	Y
SP550-SBK	SP	ANGLED 1/4" TRS	☉		Y
SP650-S	SP	ANGLED 1/4" TRS		☉	Y
SP650-SBK	SP	ANGLED 1/4" TRS	☉		Y
SPS4	SPS	STRAIGHT 1/4" TS		☉	Y
SPS4-BK	SPS	STRAIGHT 1/4" TS	☉		Y
SPS5	SPS	STRAIGHT 1/4" TS		☉	Y
SPS5-BK	SPS	STRAIGHT 1/4" TS	☉		Y
SPS6M	SPS	STRAIGHT 1/4" TS		☉	Y
SPS6M-BK	SPS	STRAIGHT 1/4" TS	☉		Y
SPS7M	SPS	STRAIGHT 1/4" TS		☉	Q4 26
SPS7M-BK	SPS	STRAIGHT 1/4" TS	☉		Q4 26
SPS6-S	SPS	STRAIGHT 1/4" TRS		☉	Y
SPS6-SBK	SPS	STRAIGHT 1/4" TRS	☉		Y
SPS7-S	SPS	STRAIGHT 1/4" TRS		☉	Y
SPS7-SBK	SPS	STRAIGHT 1/4" TRS	☉		Y
SPDC2.1A	SPDC	ANGLED 2.1MM DC POWER	☉		Q3 26
SPDC2.1	SPDC	STRAIGHT 2.1MM DC POWER	☉		Q4 26
SPDC2.5A	SPDC	ANGLED 2.5MM DC POWER	☉		Q1 27
SPDC2.5	SPDC	STRAIGHT 2.5MM DC POWER	☉		Q1 27
SP3.5	SP3.5	ANGLED 1/8" TS	☉		Q2 27
SPS3.5	SP3.5	STRAIGHT 1/8" TS	☉		Q2 27
SP3.5-S	SP3.5	ANGLED 1/8" TRS	☉		Q3 27
SPS3.5-S	SP3.5	STRAIGHT 1/8" TRS	☉		Q3 27

## SP Cables The Next Evolution In Audio Connectivity

SP Cables delivers a streamlined range of microphone, balanced patch, instrument, and pedalboard cables, all engineered with the same precision standards.

Each cable is designed for low capacitance, robust shielding, and consistent signal transfer, ensuring clarity and reliability in any application.

## O1. Series: quad-core balanced microphone cables

SP microphone cables are precision engineered for professional audio applications, delivering exceptional signal integrity, durability, and mechanical resilience.

Built around a quad core balanced design, they provide superior common mode noise rejection while also improving electromagnetic interference immunity, phase stability, and overall signal clarity over long cable runs. This architecture enhances performance in electrically noisy environments and helps maintain consistent audio fidelity under demanding conditions.

Each cable is terminated with our patented compact SPX and SPXA Series connectors, ensuring reliable, space efficient integration.

As a result, these cables are suited for a broad range of demanding professional audio environments, including live sound reinforcement, broadcast and OB production, studio recording, post production facilities, theatrical sound systems, touring rigs, and permanent installed audio infrastructures.

Available in four connector configurations (O1.A, O1.B, O1.C and O1.D), with 6 standard lengths offered for each: 3, 6, 10, 15, 25, and 50 ft.



## O2. Series: quad-core balanced patch cables

Our balanced patch cables are built using the same high performance microphone wire, delivering identical levels of signal integrity, durability, and mechanical resilience in a compact format.

Leveraging a quad core balanced design, they offer excellent noise rejection, enhanced immunity to electromagnetic interference, and stable signal transmission, even in high density or electrically challenging environments.

Paired with our patented compact SPX, SPXA, and SPS-S Series connectors, these patch cables provide a space efficient solution without compromising performance.

SP balanced patch cables are ideally suited for patch bays, rack systems, and interconnect applications across live sound, broadcast, studio, and installed audio environments where reliability, clarity, and efficient cable management are essential.

Available in 4 connector configurations (O2.A, O2.B, O2.C and O2.D), with four standard lengths offered for each: 3, 6, 10, and 15 ft.



### 03. Series: low capacitance instrument cables

SP instrument cables are built around a proprietary ultra low capacitance unbalanced design rated at just 70pF/m [21pF/ft], delivering extended high-frequency response, enhanced clarity, and a tight, punchy tone. The construction incorporates dual semi-conductive shield layers combined with a 97% coverage spiral shield, minimizing microphonics while providing excellent electromagnetic interference rejection.

With an overall diameter of just under 6.5mm, these cables offer superior flexibility and handling, while maintaining a low capacitance performance typically associated with larger cables in the 7.5-8.0mm OD range.

Our instrument cables are available with a choice of connector configurations to suit different usage environments.

For standard and everyday applications, they are fitted with the compact SPS6M and SP600 connectors, offering a low profile solution with reliable performance in fixed installations and regular use scenarios.

For touring, stage, and other high cycle environments requiring frequent mating and unmating, they are available with SPS7M and SP700 connectors, engineered for increased durability and mechanical robustness under demanding conditions.

Available in 4 connector configurations (03.A, 03.B, 03.D and 03.E), with five standard lengths offered for each: 3, 6, 10, 15, and 20 ft.



## O4. Series: low capacitance pedalboard cables

SP pedalboard cables are designed to deliver an optimal balance of compact form factor, flexibility, and high-fidelity audio performance for both pedalboard and rack integration.

With a low capacitance of 80 pF/m [24 pF/ft], they ensure accurate signal transfer and preserved high frequency detail even in complex signal chains.

The construction features a slim 4.5 mm outer diameter for maximum routing flexibility, alongside a semi-conductive layer and a 97% coverage spiral shield for effective rejection of noise and microphonics.

Combined with compact SP400 and SPS4 angled and straight connectors, these cables provide a reliable and space efficient solution for high density, performance critical wiring applications.

Available in 3 connector configurations (O4.A, O4.B, and O4.C), with multiple standard lengths offered for each: 4, 6, 8, 10, 12, and 20 in.

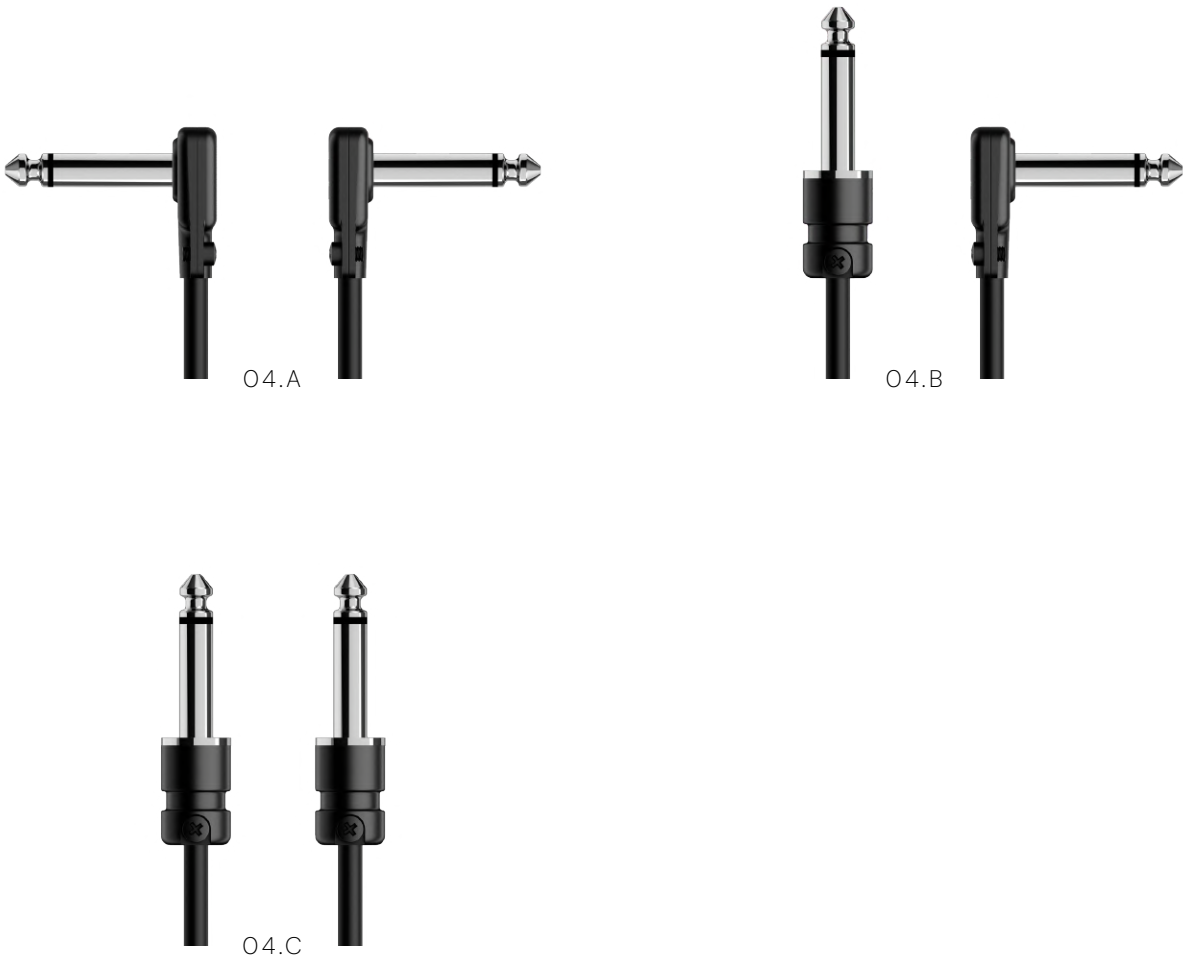

CABLE MODEL No. SPC1805-Q

APPLICATION	BALANCED SIGNALS	
USED IN	01 + 02 SERIES	
No. OF CONDUCTORS	4 – STAR QUAD CONFIGURATION	
CONDUCTOR	MATERIAL SIZE	OXYGEN FREE COPPER AWG 24
INSULATION	MATERIAL NOMINAL DIAMETER COLOR	XLPE 1.4 MM ± 0.1 MM – 0.06 IN ± 0.004 IN BLUE / CLEAR
SHIELD	MATERIAL TYPE COVERAGE	OXYGEN FREE COPPER SPIRAL 95% – 97%
CAPACITANCE AT 1 kHz	COND. – COND. COND. – SCREEN	63 pF/M ± 5% – 19.2 pF/FT ± 5% 100 pF/M ± 5% – 30.5 pF/FT ± 5%
CONDUCTOR RESISTANCE	0.085 OHM/M ± 5%	
JACKET	MATERIAL COLOR NOMINAL DIAMETER	PVC BLACK 6.5 MM ± 0.1 MM – 0.256 IN ± 0.004 IN
SOLDER	ROHS LEAD-FREE SN 99.3 %, CU 0.7 %	

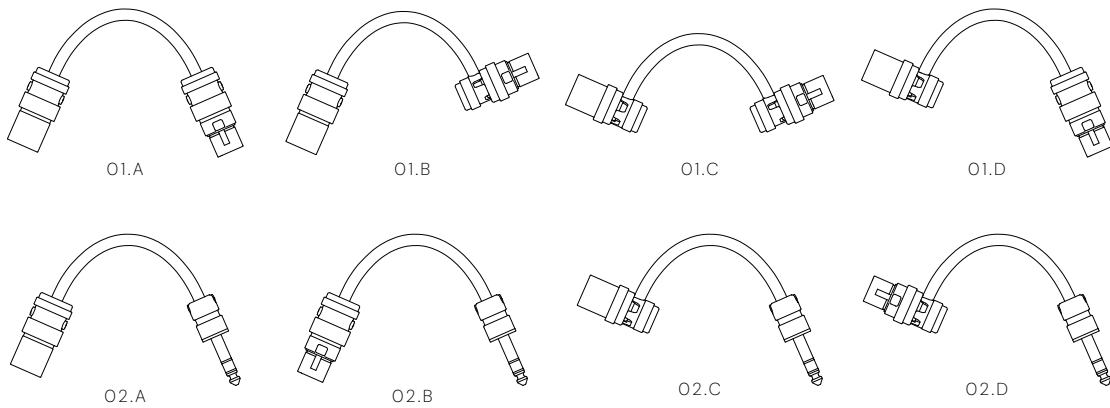

CABLE MODEL No. SPC4718



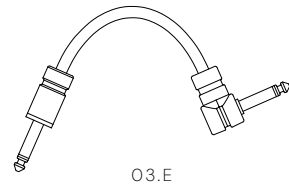
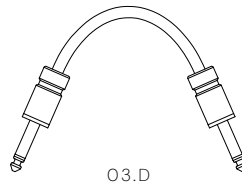
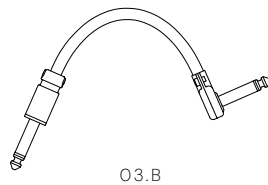
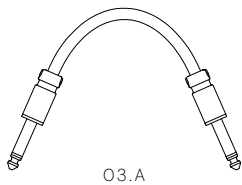





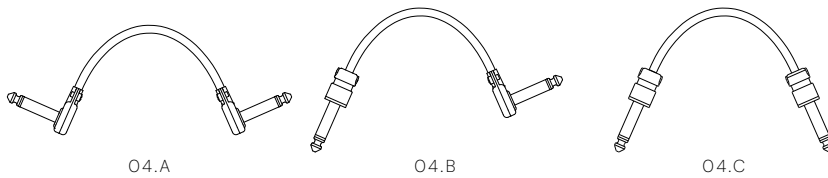

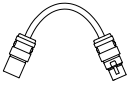

USED IN	03 SERIES	
APPLICATION	UNBALANCED SIGNALS	
No. OF CONDUCTORS	1 – COAX CONFIGURATION	
CONDUCTOR	MATERIAL SIZE	OXYGEN FREE COPPER AWG 24
INSULATION 1	MATERIAL NOMINAL DIAMETER	PE 1.9 MM ± 0.1 MM – 0.08 IN ± 0.004 IN
INSULATION 2	MATERIAL NOMINAL DIAMETER	PVC 2.5 MM ± 0.1 MM – 0.1 IN ± 0.004 IN
SHIELD	MATERIAL TYPE COVERAGE	OXYGEN FREE COPPER SPIRAL 95% – 97%
CAPACITANCE AT 1 kHz	COND. – SCREEN	70 pF/M ± 5% – 21 pF/FT ± 5%
CONDUCTOR RESISTANCE	0.08 OHM/M ± 5%	
JACKET	MATERIAL COLOR NOMINAL DIAMETER	PVC BLACK 6.3 MM ± 0.1 MM – 0.24 IN ± 0.004 IN
SOLDER	ROHS LEAD-FREE SN 99.3 %, CU 0.7 %	

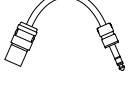
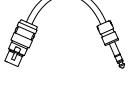
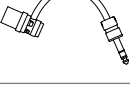
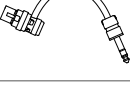

CABLE MODEL No. SPC0805

APPLICATION	UNBALANCED SIGNALS	
USED IN	04 SERIES	
No. OF CONDUCTORS	1 – COAX CONFIGURATION	
CONDUCTOR	MATERIAL SIZE	OXYGEN FREE COPPER AWG 24
INSULATION 1	MATERIAL NOMINAL DIAMETER	PE 1.9 MM ± 0.1 MM – 0.08 IN ± 0.004 IN
INSULATION 2	MATERIAL NOMINAL DIAMETER	PVC 2.5 MM ± 0.1 MM – 0.1 IN ± 0.004 IN
SHIELD	MATERIAL TYPE COVERAGE	OXYGEN FREE COPPER SPIRAL 95% – 97%
CAPACITANCE AT 1 kHz	COND. – SCREEN	80 pF/M ± 5% – 24 pF/FT ± 5%
CONDUCTOR RESISTANCE	0.08 OHM/M ± 5%	
JACKET	MATERIAL COLOR NOMINAL DIAMETER	PVC BLACK 4.5 MM ± 0.1 MM – 0.18 IN ± 0.004 IN
SOLDER	ROHS LEAD-FREE SN 99.3 %, CU 0.7 %	



	SUB SERIES	TYPE / DESCRIPTION / COFIGURATION	STANDARD LENGTHS	AVAILABILITY
	01.A	STRAIGHT XLR M – STRAIGHT XLR F QUAD CORE BALANCED MICROPHONE CABLE SPX-MBK / SPC1805-Q / SPX-FBK	3, 6, 10, 15, 25, 50 FT	Y
	01.B	STRAIGHT XLR M – ANGLED XLR F QUAD CORE BALANCED MICROPHONE CABLE SPX-MBK / SPC1805-Q / SPXA-FBK	3, 6, 10, 15, 25, 50 FT	Y
	01.C	ANGLED XLR M – STRAIGHT XLR F QUAD CORE BALANCED MICROPHONE CABLE SPXA-MBK / SPC1805-Q / SPX-FBK	3, 6, 10, 15, 25, 50 FT	Y
	01.D	ANGLED XLR M – ANGLED XLR F QUAD CORE BALANCED MICROPHONE CABLE SPXA-MBK / SPC1805-Q / SPXA-FBK	3, 6, 10, 15, 25, 50 FT	Y
	02.A	STRAIGHT XLR M – STRAIGHT 1/4" TRS QUAD CORE BALANCED PATCH CABLE SPX-MBK / SPC1805-Q / SPS6-SBK	3, 6, 10, 15 FT	Y
	02.B	STRAIGHT XLR F – STRAIGHT 1/4" TRS QUAD CORE BALANCED PATCH CABLE SPX-FBK / SPC1805-Q / SPS6-SBK	3, 6, 10, 15 FT	Y
	02.C	ANGLED XLR M – STRAIGHT 1/4" TRS QUAD CORE BALANCED PATCH CABLE SPXA-MBK / SPC1805-Q / SPS6-SBK	3, 6, 10, 15 FT	Y
	02.D	ANGLED XLR F – STRAIGHT 1/4" TRS QUAD CORE BALANCED PATCH CABLE SPXA-FBK / SPC1805-Q / SPS6-SBK	3, 6, 10, 15 FT	Y
	03.A	STRAIGHT 1/4" TS – STRAIGHT 1/4" TS LOW CAPACITANCE INSTRUMENT CABLE SPS6M-BK / SPC4718 / SPS6M-BK	3, 6, 10, 15, 20 FT	Y
	03.B	STRAIGHT 1/4" TS – ANGLED 1/4" TS LOW CAPACITANCE INSTRUMENT CABLE SPS6M-BK / SPC4718 / SP600BK	3, 6, 10, 15, 20 FT	Y
	03.D	STRAIGHT 1/4" TS – STRAIGHT 1/4" TS LOW CAPACITANCE INSTRUMENT CABLE SPS7M-BK / SPC4718 / SPS7M-BK	3, 6, 10, 15, 20 FT	Q3 26
	03.E	STRAIGHT 1/4" TS – ANGLED 1/4" TS LOW CAPACITANCE INSTRUMENT CABLE SPS7M-BK / SPC4718 / SP700BK	3, 6, 10, 15, 20 FT	Q3 26
	04.A	ANGLED 1/4" TS – ANGLED 1/4" TS LOW CAPACITANCE PEDALBOARD CABLE SP400BK / SPC0805 / SP400BK	4, 6, 8, 10, 12, 20 IN	Y
	04.B	STRAIGHT 1/4" TS – ANGLED 1/4" TS LOW CAPACITANCE PEDALBOARD CABLE SPS4-BK / SPC0805 / SP400BK	8, 10, 12, 16, 20 IN	Y
	04.C	STRAIGHT 1/4" TS – STRAIGHT 1/4" TS LOW CAPACITANCE PEDALBOARD CABLE SPS4-BK / SPC0805 / SPS4-BK	BUILT TO ORDER	Y

ORDERING: SPECIFY THE CABLE CONFIGURATION BY SELECTING THE APPROPRIATE SUB SERIES CODE, FOLLOWED BY THE REQUIRED CABLE LENGTH SEPARATED BY A COMMA.

FORMAT: SUB SERIES – LENGTH (FT OR IN).

EXAMPLE: 01.A-6 CORRESPONDS TO A 6 FT (1.8 M) STRAIGHT XLR MALE TO STRAIGHT XLR FEMALE MICROPHONE CABLE.

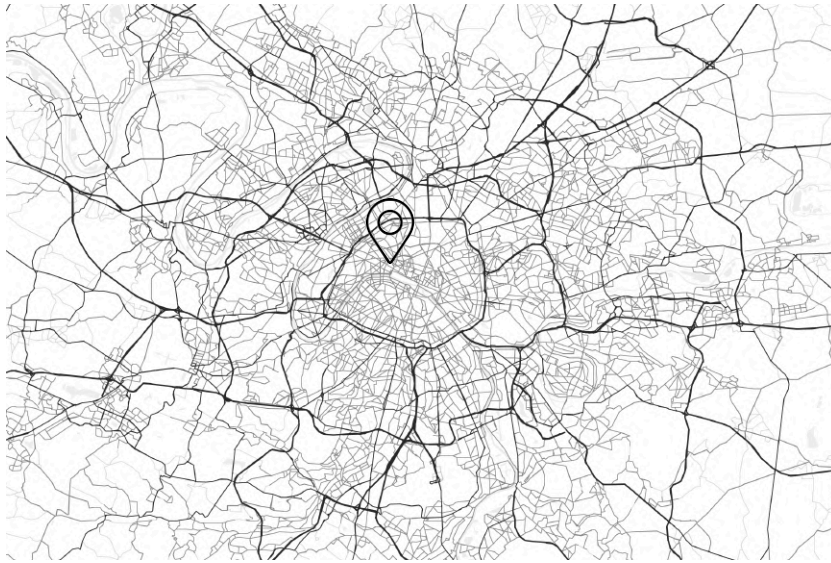

EUROPE OFFICE  
07 RUE DE CASTELLANE, 75008 PARIS, FRANCE  
+33 682 774 770



NORTH AMERICA OFFICE  
1015 GAYLEY AVE., LOS ANGELES CA90024, UNITED STATES  
+1 310 405 9279



AUSTRALIA REPRESENTATION – KRONIG SUPPLY  
866 BOURKE ST, WATERLOO – SYDNEY, NSW 2017, AUSTRALIA  
+61 478 478 401